

THREE INPUT DOOR SENSA

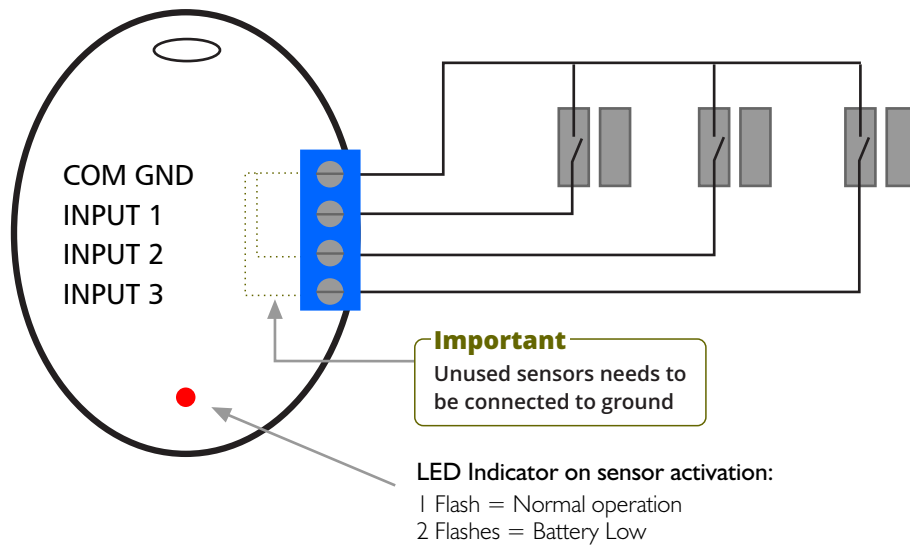

DOOR SENSA INSTALLATION NOTES

1

- Mount DIN rail receiver in DB board.
- For best signal strength antenna must be mounted out of DB board housing.
- Antenna must never be cut.

2

Mount Door Sensa and Magnetic Switches at door or windows

3 Hold the receiver LINK button until the LED starts flashing

4 Then activate one magnetic input within 25 sec

BATTERY REPLACEMENT

Pull Battery out from the top Insert new Battery from the side

1 **2** **3**